

### F-1.6 1U Rackmount Fan Tray

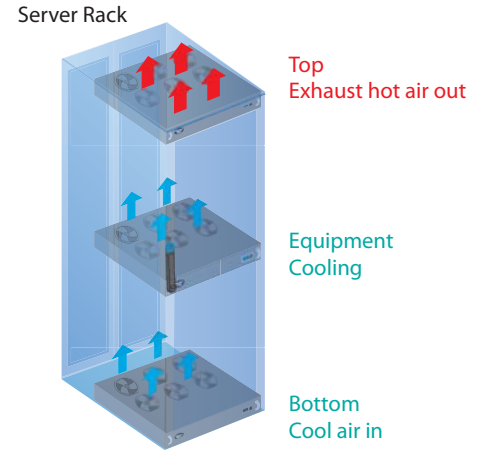

#### Features & Benefits

- ▶ Designed for low noise / high airflow performance
- ▶ External temperature sensor x 1
- ▶ Front temperature LED
- ▶ Auto-sensing 110V to 220VAC power input
- ▶ 48V, 24V or 12VDC power option

#### External Temperature Sensor



- Plug & Play
- 2M wire



#### Diagrams ( mm )

Top View

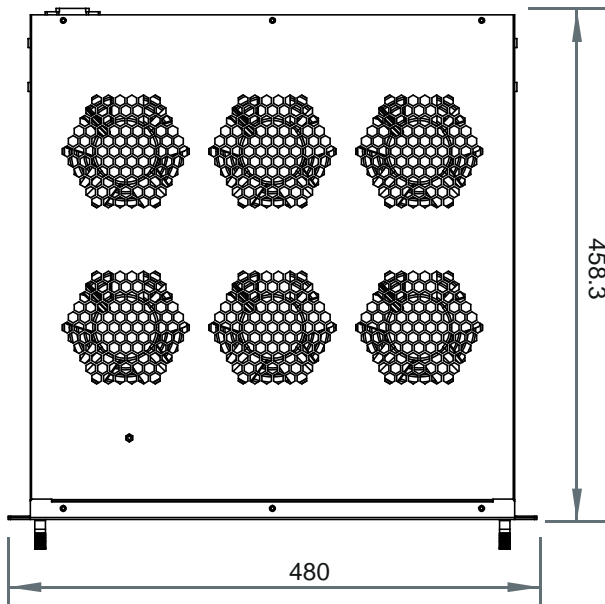

Front View

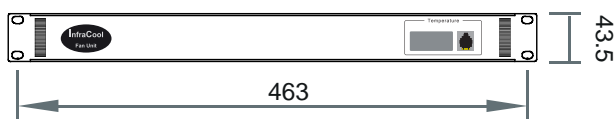

#### Specifications

##### • F-1.9 Fan Tray

No. of Fans :	6
Individual Fan CFM :	108 CFM
Unit CFM ( approx. ) :	648 CFM
MTBF :	50,000 hrs
Individual Fan Noise Level :	41 dB

##### • Environmental

Operating :	0 to 50°C Degree
Storage :	-5 to 60°C Degree
Relative humidity :	5~90%, non-condensing
Shock :	50G peak acceleration ( 11ms, half-sine wave )
Vibration :	58~100Hz / 0.98G ( 11ms / cycle )

##### • Weight

Net / Gross :	6.8 kgs ( 15 lbs ) / 8 kgs ( 17.6 lbs )
---------------	---

##### • Casing Color :

Black

##### • Mounting :

1U rackmount

##### • Safety Regulatory :

FCC & CE certified

##### • Environmental :

RoHS2 & REACH compliant by SGS

##### • Power

Input :	Auto-sensing 100V or 240V AC at 50 or 60Hz via IEC cord
Consumption :	40W

##### • Dimensions

Product :	480 x 458.3 x 43.5 mm / 18.9 x 18 x 1.71 inch
Packing :	550 x 550 x 120 mm / 21.7 x 21.7 x 4.7 inch